

Accufab 96-98 Cobra Mustang Throttle Body Installation Guide



The below installation instructions work for the following products:

- 2001 Bullitt and 1996-1998 Cobra Accufab Throttle Body



This installation refers to the following product: **1996-1998 Cobra Throttle Body.**

If you are looking for more throttle response in your SN-95 4.6L Cobra, you definitely want an Accufab throttle body. When purchasing this throttle body you will need to take into account that there is a slight modification needed to be done to the plenum in order to get the throttle body to fit and perform properly. Therefore, because I have installed this throttle body on my 1996 Cobra, I will guide you through the installation process of this particular throttle body.

NOTE: If you are not comfortable with making cuts into aluminum please have a professional do this installation. AmericanMuscle.com and myself will not be responsible for any damages caused by installation damages.

Tools Required:

- A Dremel Rotary Tool
- Two or Three Fiberglass Reinforced Cutting Wheel for the Dremel
- Shop Towels
- Flathead Screwdriver
- A Metric Ratchet Set
- Magnet for Dropped Bolts and Screws
- Safety Goggles

Installing Your **Accufab 96-98 Cobra Throttle Body** in your SN-95 Cobra

- **Preparing for Plenum Removal**

My installation procedure will vary slightly from Accufab's install instructions on their website. Accufab says you can do the installation with the manifold on the car. This can be done to cut time down on the install; however, metal shavings will go everywhere when you start to cut with the Dremel. Therefore, this install will actually have you removing the upper manifold and plenum from the car.

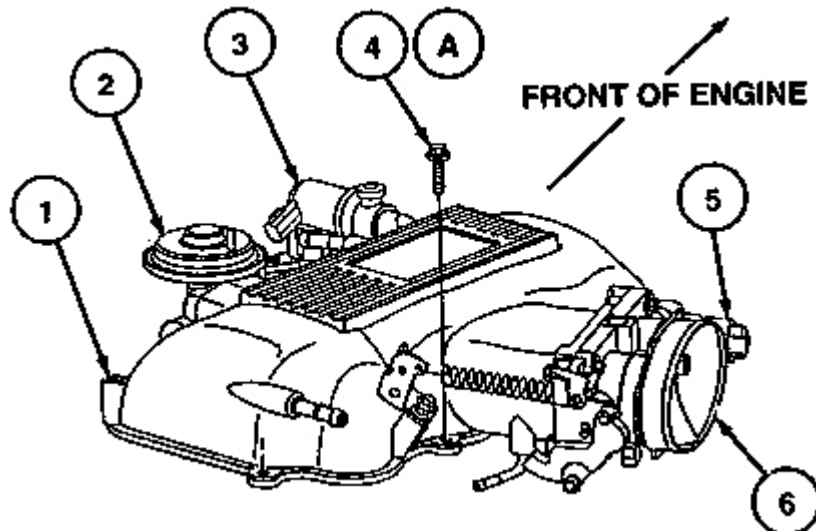

1. Disconnect the battery.
2. Unscrew your intake pipe from your factory **Mustang throttle body**. It is only held on by a band clamp and a flat headed screw.
3. Disconnect your throttle position sensor (#5) from the wiring harness. It is only connected by a simple clip that can normally be removed by just using your fingers.
4. Remove all of the accessories from the upper intake. These are all held on by either 8mm or 10mm bolts.
5. There are only two things that will need to be unbolted from the upper manifold: your IAC Sensor (#3) and your EGR (#2). Both are held on by two bolts and both have a metal gasket in between the accessory and the manifold. Make sure you keep these and set them aside.
6. The only other things you will need to disconnect is a rubber tube underneath the plenum elbow, and the vacuum line that is on back left side of the plenum, which is also a rubber piece. The rubber lines are connected to the two barbs at the bottom of the image.
7. Remove the accelerator cable, cruise control cable, and tension spring from the throttle body.
8. You should notice that there is a bracket that holds the cables over the manifold. Unbolt that bracket and move the cables aside.
9. After the accessories are disconnected look for the six bolts that hold the upper manifold onto the lower manifold and remove them.
10. Remove the upper manifold. Watch out for the composite gasket in between the upper and lower manifolds. You do not want to cut or lose this gasket, as it is not cheap to replace. Luckily, you can re-use the gasket, so you don't have to buy a new one. Let's hear it for Ford and their engineering team!

11. Cover up your exposed intake with a towel or something of the sort and shut your hood. Head on into your garage or shop area.

- **Removal of the Stock Throttle Body and Modifying the Plenum**

1. Removal of the stock throttle body is quite simple. All you need to do is unbolt the four bolts that hold it into place.
2. There is a gasket that is between the stock throttle body and the upper manifold. Remove that and toss it in the trash. Accufab gives you a new gasket.
3. Now you should see the problem of why the manifold has to be modified. The plenum is setup for the stock throttle body, which is a twin bore throttle body. There is an aluminum piece that is in the center of the opening that is about 4-5mm thick. This is what we will be removing.
4. Go ahead and get your Dremel out and put on the fiberglass reinforced wheel.
5. Take your intake and lay it flat so that it is not rocking everywhere. You might want to consider stuffing the inside of the intake with a towel or something of the sort to keep aluminum shavings out.

(Click for Larger Image)

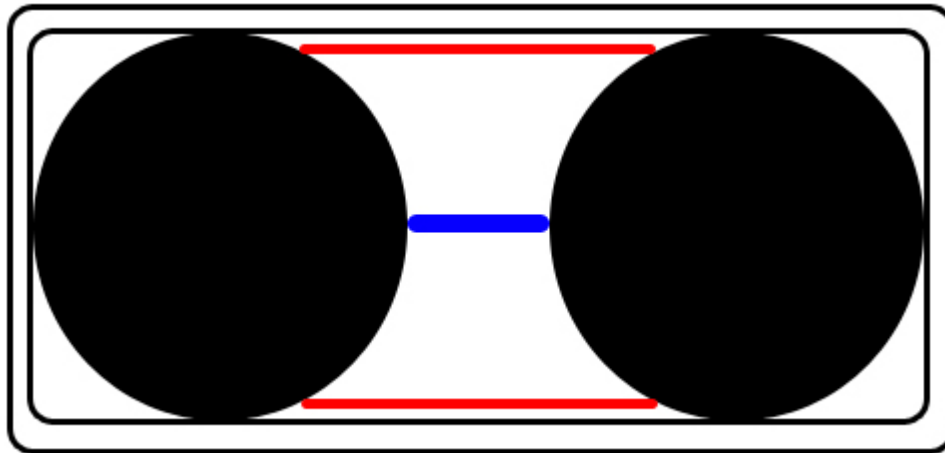

NOTE: If you refer to the image above, the red lines are where your cuts need to be. Please note that the lines are in approximate positions. If you want an exact template, take the gasket provided by Accufab and mark off where the top and bottom sit. Make your cut just SLIGHTLY above that line, as you don't want to cut into the elbow itself. Look for yourself and make sure that when you make your cut, you are actually cutting through the aluminum separator and not the intake elbow. I personally suggest making the cut where the blue line is so that the piece can be removed in 2 sections. Cutting it to be removed in one full piece can sometimes be more difficult, as the angle of the Dremel to make the cut is sometimes prohibited by the extra mass. This will also give you a chance to see how long it will take to get all the way through the aluminum. **TAKE YOUR TIME!** You do not want to rush this step. The aluminum is quite thick and can be tedious to remove. Keep your RPM's on your Dremel in the middle to mid-high range. If it is going too fast, the wheel will shatter; and if it is going too slow, you won't be able to make your cut.

- **Fitment Check and Reinstallation**

1. Once you have finished your cuts, it is smooth sailing. Take your new Accufab throttle body and check the fitment, making sure that the blade can open all the way, and close all the way
2. If you are finding that the blade is hitting any portion of your cut, take the throttle body off and slice a little more off until the blade can clear completely. If it can, you are about 80% done. It's time to wrap this install up.
3. Take your old throttle body and remove the TPS sensor from the side. It is held on by two screws.
4. Transfer the TPS sensor to the new throttle body and screw it in with the screws that Accufab provides.
5. After transferring the TPS, bolt the new throttle body onto the newly modified plenum. Make sure you put the gasket provided between the plenum elbow and the throttle body before bolting the new throttle body all the way into place.
6. Now, reverse the removal of the intake to reinstall.
7. Bolt down the upper intake bolts hand tight and then tighten just a little more.
8. After doing that, reconnect the bracket to the manifold
9. Then reconnect the cables back to their respective positions on the throttle body.
10. Snap the throttle position sensor connector back into place
11. Reconnect the EGR and IAC as well as the rubber tubing that are on the backside of the intake.
12. After that, reconnect your intake tube to the throttle body, clamp it down, reconnect the battery, and start it up!

Find more **how-tos, instructions** and **videos** at www.americanmuscle.com!