

## INSTALLATION INSTRUCTIONS

### 57-2532 Ford 1999-04 Mustang V6-3.8L

#### TOOLS NEEDED:

8mm wrench  
10mm wrench  
13mm wrench  
9/16" wrench  
Flat blade screwdriver  
Side cutters

#### PARTS LIST:

A Hose clamp, #44	2	08577	G Plug	1	21684	M Bracket, "F"	1	26667	S 6mm Hex bolt	2	07703
B Silicone hose	1	08179	H Hose clamp #56	1	08620	N 6mm Nylock nut	2	07553	T Adapter	1	21504
C Hose, 10mm x 10"L	1	08102	I Silicone step hose	1	08051	O 1/4" Flat washer	4	08275	U Hose clamp, #104	1	08697
D Vent, 3/8"	1	080023	J Hose clamp, #48	1	08601	P Gasket	2	09330	V Air filter	1	RC4940
E Intake tube	1	087026	K 6mm Hex bolt	4	07865	Q Heat shield	1	07445			
F Grommet	1	08092	L 6mm Wave washer	4	08174	R Edge trim, 26"L	1	102488			

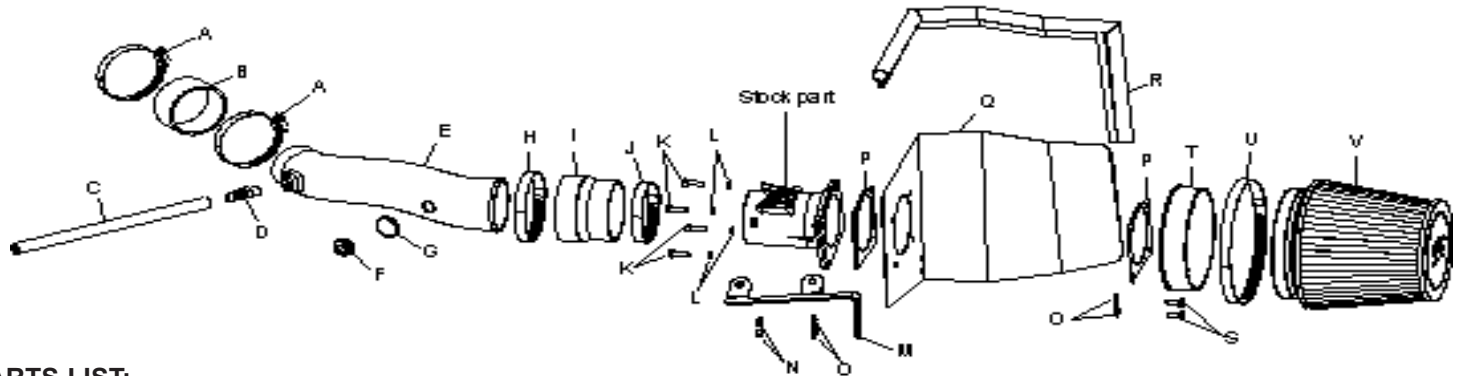

**NOTE: FAILURE TO FOLLOW INSTALLATION INSTRUCTIONS AND NOT USING THE PROVIDED HARDWARE MAY DAMAGE THE INTAKE TUBE, THROTTLE BODY AND ENGINE.**

#### TO START:

1. Turn the ignition OFF and disconnect the vehicle's negative battery cable.



2. Disconnect the secondary mass air sensor electrical connection as shown.



3. On 1999-2000 vehicles remove the air temperature sensor from the rubber intake as shown.



4. Disconnect the crank case vent hose from the rubber intake as shown.



5. Using a flat blade screwdriver loosen the hose clamps at the throttle body and at the air cleaner, then, remove the rubber intake hose as shown.



6. Using a 8mm wrench or nut driver, loosen and remove the bolt that secures the air cleaner to the inner fender as shown.



7. Pull firmly upwards to release the air cleaner from the factory grommets, then remove the air cleaner as shown.

**Note: K&N recommends that customers do not discard factory air intake.**



8. Release the over-center clamps on the air cleaner to separate the two halves as shown.



9. Using a flat blade screwdriver, depress the tabs to release the mass air sensor cover from the mass air sensor base plate as shown.



10. Disconnect the mass air sensor electrical connection from the mass air sensor as shown.

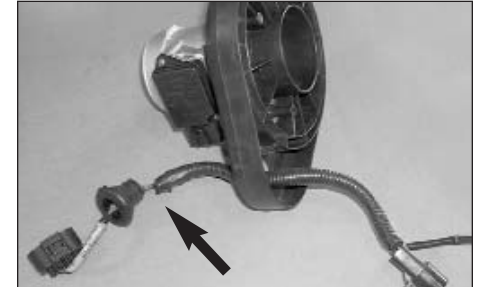

11. Remove the mass air sensor wire harness from the base plate as shown.



12. Using a 10mm wrench or nut driver loosen and remove the two bolts that secure the mass air sensor, then, remove the mass air sensor from the base plate as shown.

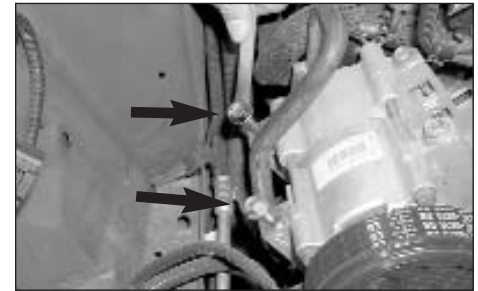

13. Using a 13mm wrench loosen and remove the two lower A/C compressor bolts as shown.



14. Using the provided hardware assemble the mass air adapter, heat shield, gaskets, and the mass air sensor as shown using a 10mm wrench or nut driver.



15. Using the provided hardware, assemble the support bracket onto the heat shield using a 10mm wrench as shown.



16. Install the provided trim seal onto the heat shield assembly as shown. Trim excess if necessary using side cutters.



17. Install the provided silicone hose and hose clamps onto the K&N intake tube as shown.



18. On 1999-2000 vehicles install the provided grommet into the hole on the K&N intake tube, then, install the air temperature sensor into the grommet as shown.

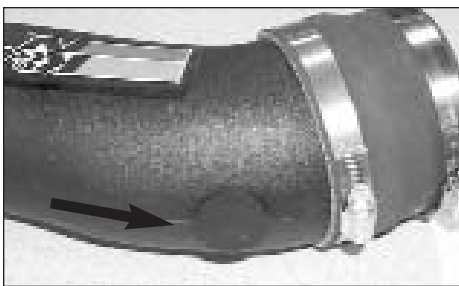

19. On 2001 vehicles install the rubber plug into the hole on the K&N intake tube.

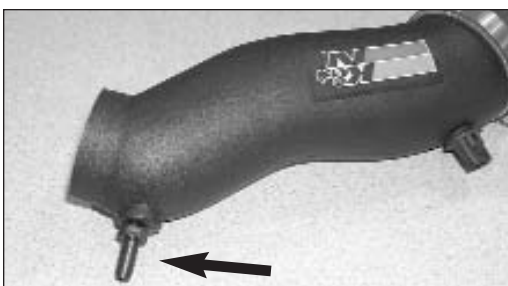

20. Install the 3/8" vent into the K&N intake tube with a 9/16" wrench as shown.



21. Slide the K&N intake tube onto the mass air sensor as shown, but do not tighten completely.



22. Install the provided silicone hose and hose clamps onto the throttle body as shown.



23. Slide the K&N intake assembly into the silicone hose on the throttle body as shown.



24. Line up the support bracket with the A/C compressor and secure with the original bolts removed in step 13 using a 13mm wrench.

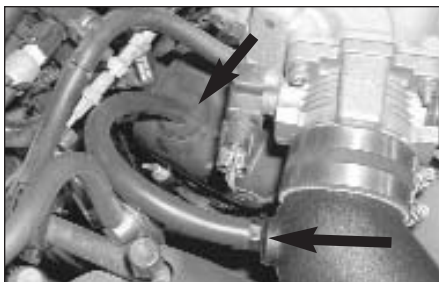

25. Install the provided hose onto the vent on the cam cover, then, reconnect the hose to the 3/8" vent on the K&N intake tube.



26. Install the K&N Air filter and secure with the provided hose clamp as shown. Adjust intake tube and tighten all clamps completely.



27. On 1999-2000 vehicles reconnect the air temperature sensor electrical connection.



28. Reconnect the vehicle's mass air sensor electrical connection as shown.



29. Reconnect the negative battery cable, then double check to make sure everything is tightened and properly positioned before starting the vehicle.

30. The C.A.R.B. exemption sticker, (attached), must be visible under the hood so that an emissions inspector can see it when the vehicle is required to be tested for emissions. California requires testing every two years, other states may vary.

31. It will be necessary for all FIPK's to be checked periodically for realignment, clearance and tightening of all connections. Failure to follow the above instructions or proper maintenance may void warranty.

#### ROAD TESTING:

1. Start the engine with the transmission in neutral or park, and the parking brake engaged. Listen for air leaks or odd noises. For air leaks secure hoses and connections. For odd noises, find cause and repair before proceeding. This kit will function identically to the factory system except for being louder and much more responsive.

2. Test drive the vehicle. Listen for odd noises or rattles and fix as necessary.

3. If road test is fine, you can now enjoy the added power and performance from your kit.

4. K&N suggests checking the Air filter element periodically for excessive dirt build-up. When the element becomes covered in dirt (or once a year), service it according to the instructions on the Recharger service kit, part number 99-5050 or 99-5000.