



V1.1 - 10.2014 - Outside North America ONLY -
 EURO System
 PN: 21-11031-02 QuickLIFT PLUS
 PN: 21-11031-03 QuickLIFT ELITE

This manual is property of Redline Tuning LLC. Any unauthorized duplication or use without written permission from Redline Tuning LLC, violates Copyright laws. Copyright © 2014-15 Redline Tuning LLC. All Rights Reserved.



2015+ Ford Mustang - EURO QuickLIFT Installation Guide

Patent Pending system

Step 1 - Unpack QuickLIFT system and verify contents.

Remove all items from the packing tube. You should have the following components before beginning:

- * (2) Gas springs (**RT-QL-133-55A**)
- * (2) Fender brackets with bolt and red-insert **PN 55-00015**
- * (1) Left-Hand hood bracket **PN 32-00012**
- * (1) Right-Hand hood bracket **PN 32-00013**
- * (1) Plastic drill guide used for battery cover **PN 38-00009**

Applications: 2016+ Shelby GT350 use **ONLY** part number (21-11030-02,-03), otherwise (21-11028-02,-03) will fit all other 2015+ North American Ford Mustangs with stock & aftermarket hoods. Outside North America - use QuickLIFT system part number (21-11031-02, -03)

Step 2 - Gather the required tools.

Please gather the following tools before you begin the installation:

- * Socket wrench with 13mm deep-well socket.
- * 3/4" or 19mm drill bit and electric drill.
- * Center punch

Step 3 - Install hood brackets - Right Hand (RH) and Left Hand (LH)

- A. Remove the hood's RH upper most hinge bolt using a socket wrench with a 13mm socket.
- B. The RH bracket goes onto the right-hand side of the vehicle (from the driver's perspective). The bracket will go over the upper hinge stud, then rotate counter-clockwise until it touches the flange as shown.
- C. Tighten nut back down to secure bracket.
- D. Repeat for LH side of vehicle. LH side, bracket will rotate clockwise and stop on flange.

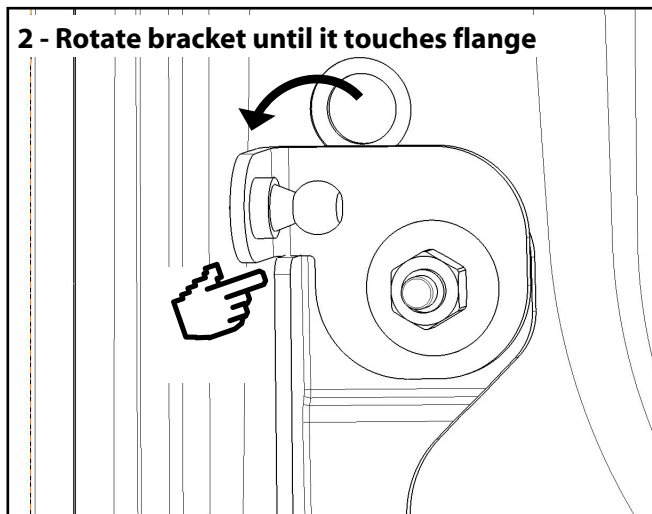
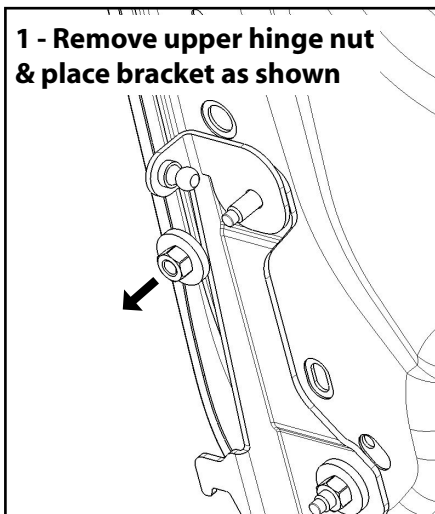

2105+ Ford EURO Mustang Hood QuickLIFT Bolt-in

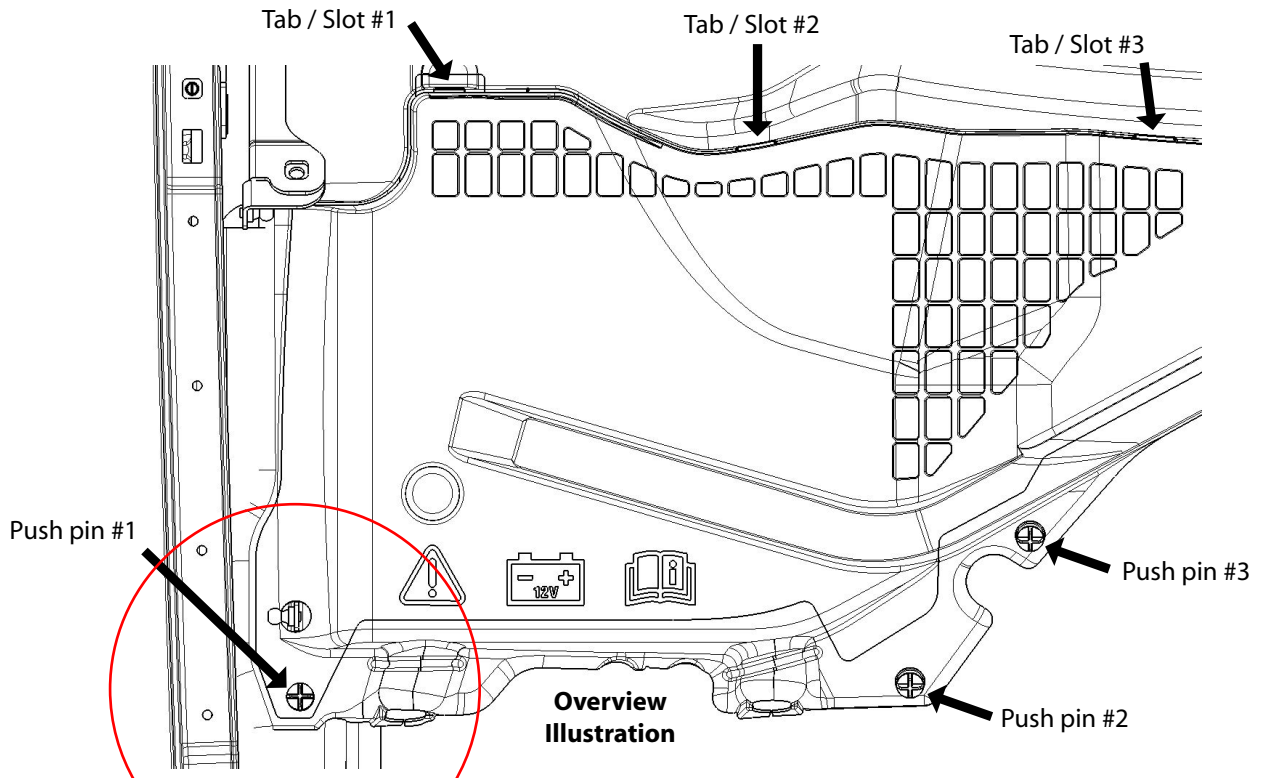

Step 4 - Position plastic guide to mark center of hole on battery cover

A. Unscrew the front push pin #1 that holds down the battery cover. Once it stops, pull out the push pin assembly easily with fingers.

(See overall illustration above for push pin location and Illustrations 1 & 2 to the right for removal).

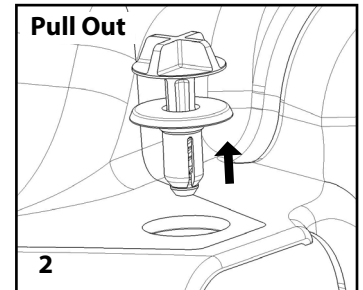
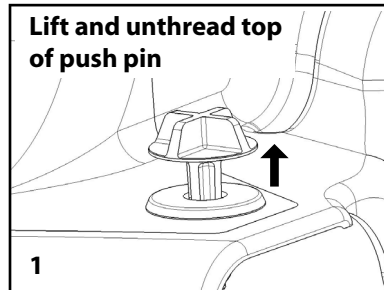

B. Insert the push-pin thru the larger hole in plastic drill guide and then back into the hole it came from. Now rotate guide until it aligns to the **plastic** edge of the battery cover - *(The border of the rubber seal surrounding the battery cover)* (Illustrations 3a & 3b)

(For right hand drive vehicles, the guide should be flipped over so it will align to your battery cover as it is a mirror image of the one shown).

C. Mark the center of the small hole at the top of the drill guide while keeping the guide aligned with the edge of the plastic as shown.

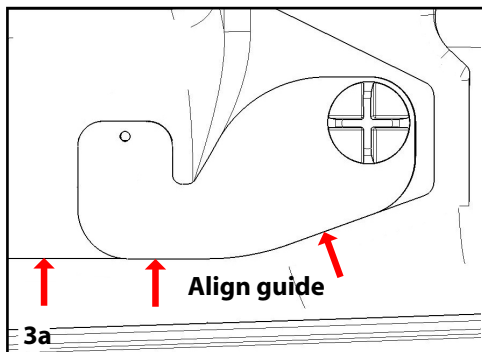

Step 5 - Remove battery cover to drill 3/4" or 19mm hole

A. Remove the (3) push-pins holding down the front of the battery cover, then remove cover by lifting slightly and pulling forward to release the three 22mm tabs at the top edge that retain it.

B. Carefully drill a small pilot hole in the plastic battery cover as marked in Step 4. Then drill the final 3/4" hole with the included step bit - entirely through the plastic. This hole is used for a pass-thru of the fender bracket installed in the next step.

OPTIONAL STEP: For easy removal of the battery cover with the QuickLIFT system installed, cut a small slot from the center of the drilled hole straight out to the edge.

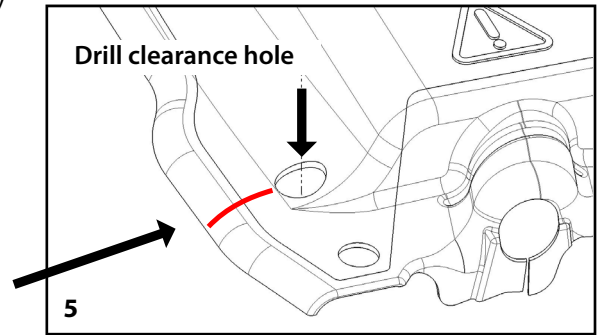

Step 6 - Install fender bracket assembly on both sides of vehicle.

A. Be sure that the bolt in the bracket assembly is threaded most of the way thru the red attachment - leave 1-2 threads of the red attachment showing from bottom.

B. Tilt and insert the red attachment through the fender hole keeping the ball-stud aiming outward or away from the vehicle - shown in Illustration 6 below.

C. With the bracket pushed down into the recessed cavity, pull up on the bolt while turning bolt clock-wise to tighten. Slowly, the assembly will tighten, compressing the bracket and fender between the red attachment (lower) and bolt (on top). **The red attachment is designed to fit perfectly in the fender slot and can be seen in the correct orientation in Illustration 9. Be sure it is aligned properly before final tightening of bolt.**

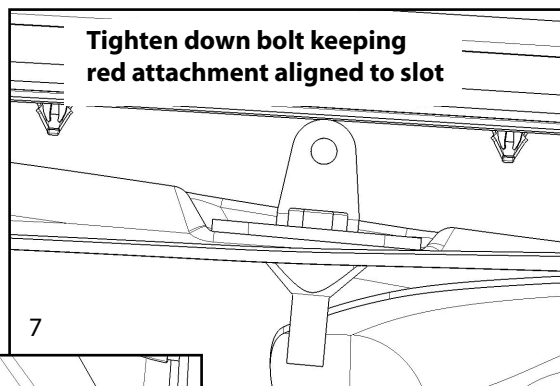
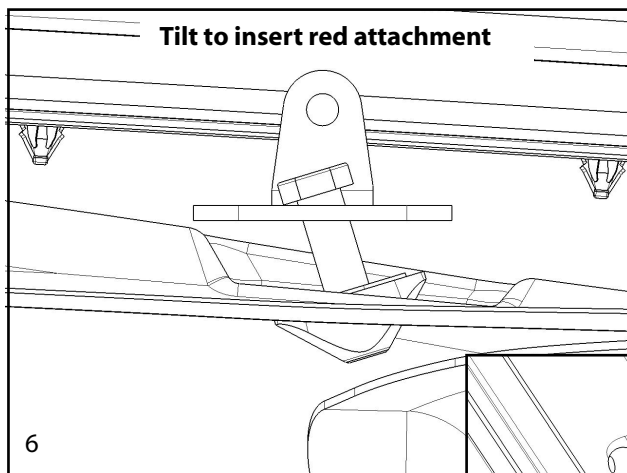

D. Repeat installation on opposite side of vehicle. Ball studs aiming outward or away from vehicle on both sides.

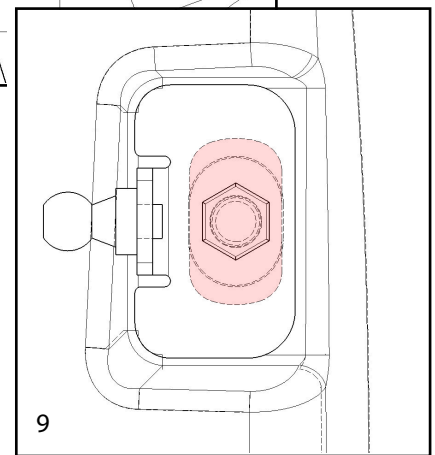
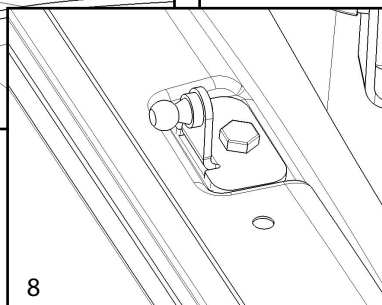

Step 7 - Reinstall battery cover.

A. Push the ball stud / bracket through the battery cover hole that was drilled.

B. Carefully align the 3 upper tabs on battery cover with the three slots on the cowl. Slide cover into slots and then reinstall the push pins into the front of the battery cover. **Be sure that the cover gets tucked back around the battery cables and is fully seated.**

Step 8 - Install gas springs.

- A. Firmly snap on the extending end of gas spring to the fender ball stud.
- B. Then snap on large end of gas spring to the hood's ball-stud. You may have to twist the socket to align to ball-stud, as well as have someone raising up the hood to center the ball & socket before snapping it on.

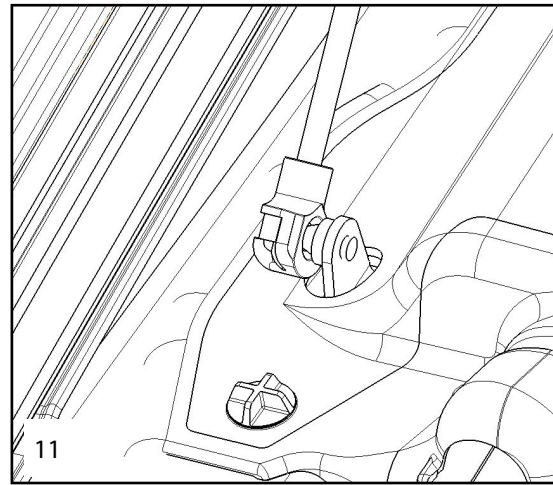
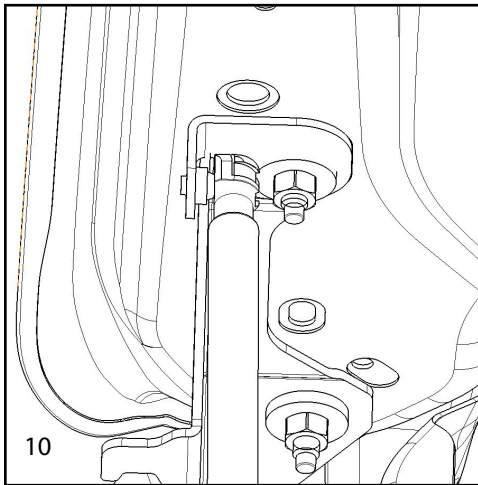

2015+ Ford Mustang QuickLIFT Bolt-in

How To Remove Struts:

Slide a small flat blade screw driver under the metal c-clip. Lift and rotate c-clip (DO NOT REMOVE C-CLIP). Gas spring will pop off of ball-stud.

Press c-clip back into position and the gas spring is ready to reinstall.

